



PDE

Guarnizioni per PISTONE
PISTON seals

TECNOTEX

Versione standard		Standard version	
Elemento di tenuta	NBR	Sealing Ring	NBR
Base	TPE	Support Ring	TPE
Anelli di Guida	POM	Guide Ring	POM
Versioni Alternative		Alternative Versions	
Base	Gommatela	Support Ring	NBR/Cotton Fabric
Base	Gommatela FKM	Support Ring	NBR/Cotton Fabric FKM
Elemento di Tenuta	NBR FKM	Sealing Ring	NBR FKM
Elemento di Tenuta	NBR Basse Temp.	Sealing Ring	NBR Low Temp.
Disponibile tagliato per pistone monoblocco		Available split for one piece pistons	
Pressione fino a / Pressure up to			
70 MPa			
Velocità fino a / Speed up to			
0.5 m/s			
Temperatura / Temperature			
-30°C +110°C		-20°C +200°C FKM	-50°C +110°C TDS 108
Applicazioni		Applications	
Escavatori		Excavators	
Siderurgia		Steel Mills	
Cilindri per Miniera		Mining Cyinders	
Cilindri per piattaforme aeree		Hydraulic Lift platforms	
Presse		Presses	



Guarnizioni per PISTONE
PISTON seals

PDE

14÷23

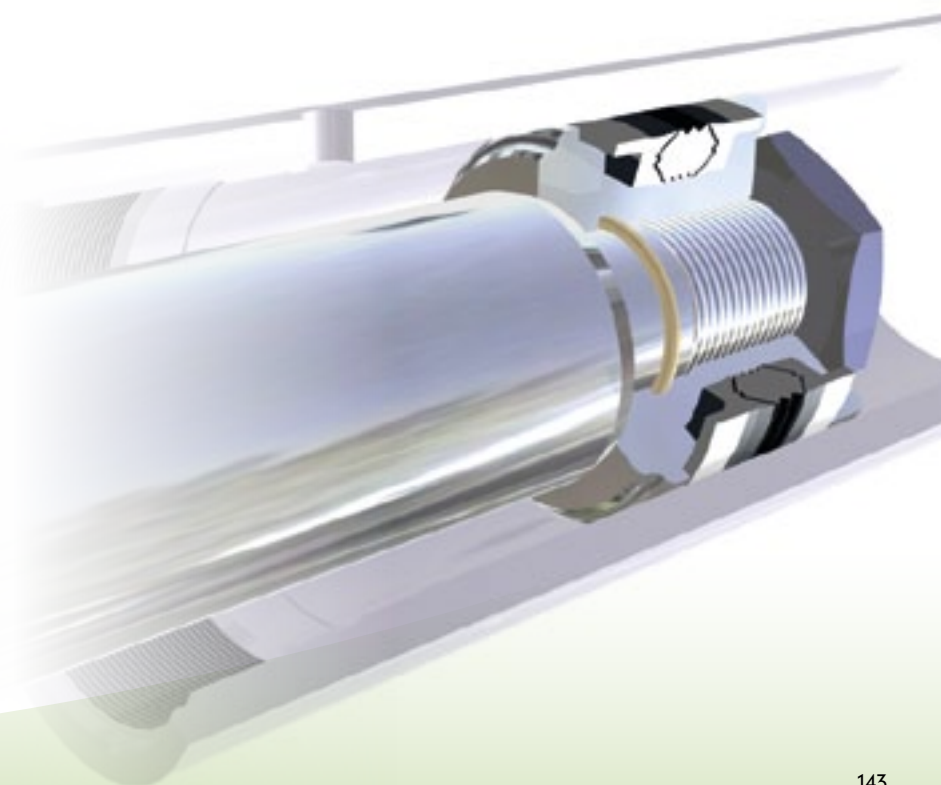

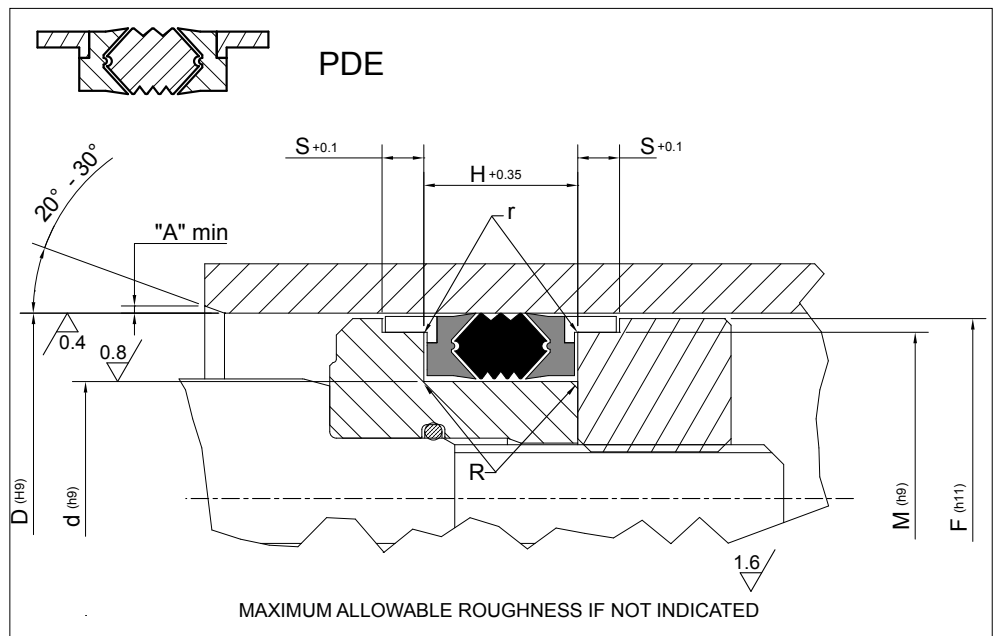

Piston Seal design guidelines

R	d ≤ 100mm		d > 100mm	
	max 0.40 mm		max 0.80 mm	
A	1 mm	2 mm	3 mm	3 mm < A ≤ 5 mm

PART NR		DIMENSIONI SEDI / Housing dimensions					
		D	d	H	S	M	F
PDE 801	177114/1	45,00	29,00	32,00	6,35	38,80	42,85
PDE 802	196133/1	50,00	34,00	32,00	6,35	43,77	47,85
PDE 803	216157/1	55,00	40,00	32,00	6,35	48,77	52,85
PDE 804	236173/1	60,00	44,00	32,00	6,35	53,80	57,80
PDE 805	248185/1	63,00	47,00	32,00	6,35	56,74	60,81
PDE 806	255192/1	65,00	49,00	32,00	6,35	58,70	62,80
PDE 807	275196/1	70,00	50,00	35,00	9,52	62,62	67,54
PDE 808	295216/1	75,00	55,00	35,00	9,52	67,70	72,54
PDE 809	314236/1	80,00	60,00	35,00	9,52	72,62	77,52
PDE 810	314251/1	80,00	64,00	32,00	9,52	72,62	77,52
PDE 811	334255/1	85,00	65,00	35,00	9,52	77,62	82,54
PDE 812	354275/1	90,00	70,00	35,00	9,52	82,58	87,79
PDE 813	354291/1	90,00	74,00	32,00	9,52	82,87	87,79
PDE 814	374295/1	95,00	75,00	35,00	9,52	87,60	92,50
PDE 815	393314/1	100,00	80,00	35,00	9,52	92,60	97,50
PDE 816	433334/1	110,00	85,00	45,00	12,70	101,82	107,33
PDE 817	433354/1	110,00	90,00	35,00	9,52	102,70	107,51
PDE 818	452354/1	115,00	90,00	45,00	12,70	106,82	112,33
PDE 819	472374/1	120,00	95,00	45,00	12,70	111,82	117,33
PDE 820	472393/1	120,00	100,00	35,00	9,52	112,80	117,51
PDE 821	492393/1	125,00	100,00	45,00	12,70	116,82	122,33
PDE 822	511413/1	130,00	105,00	45,00	12,70	121,82	127,33
PDE 822/1	511433/1	130,00	110,00	35,00	9,52	122,70	127,33
PDE 823	531433/1	135,00	110,00	45,00	12,70	126,82	132,33
PDE 824	551452/1	140,00	115,00	45,00	12,70	131,72	137,30
PDE 825	551472/1	140,00	120,00	35,00	9,52	132,70	137,30
PDE 826	570472/1	145,00	120,00	45,00	12,70	136,72	142,30

