



TTW

Guarnizioni per PISTONE
PISTON seals

TECNOLAN

Versione standard		Standard version	
Elemento di tenuta Anelli di guida	Polyurethane POM	Sealing Ring Guide Rings	Polyurethane POM
Pressione fino a / Pressure up to			
40 MPa			
Velocità fino a / Speed up to			
0.5 m/s			
Temperatura / Temperature			
-35°C +100°C			
Applicazioni		Applications	
Cilindri Idraulici Macchine movimento terra		Marine Cylinders Earth moving machinery	



GUARNITEC

Guarnizioni per PISTONE
PISTON seals

TTW

158÷161

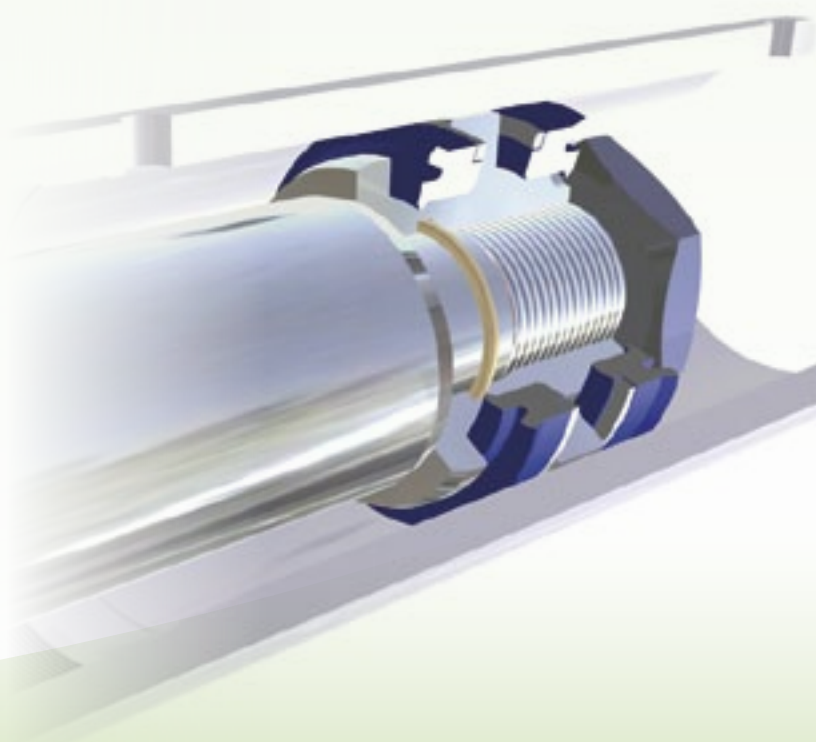

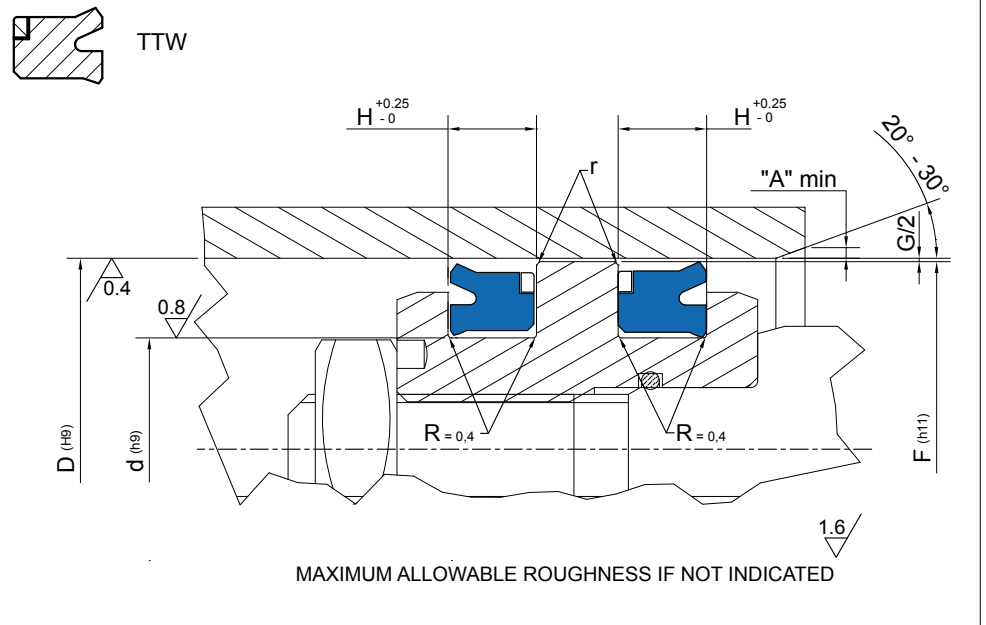

Piston Seal design guidelines

	0mm < d ≤ 50mm	50mm < d ≤ 100mm	100mm < d ≤ 150mm	d ≥ 150mm
r	remove sharp edges: r ≤ 0.3mm			
A	1 mm	2 mm	3 mm	3 mm < A ≤ 5 mm

Operating pressure to determinate Maximum Gap Allowance: G/2

G	Profile Dimension	> 16 MPa	> 26 MPa	> 32 MPa	> 40 MPa
	7.5	0.80 mm	0.70 mm	0.50 mm	0.50 mm
> 7.5		1.05 mm	0.90 mm	0.85 mm	0.80 mm

PART NR	DIMENSIONI SEDI / Housing dimensions			
	D	d	H	F
TTW 50	50,00	35,00	9,50	45,00
TTW 60	60,00	45,00	9,50	55,00
TTW 63	63,00	48,00	9,50	58,00
TTW 65	65,00	50,00	9,50	60,00
TTW 70	70,00	50,00	12,50	64,00
TTW 70/1	70,00	50,00	13,00	64,00
TTW 80	80,00	60,00	12,50	74,00
TTW 80/1	80,00	60,00	13,00	74,00
TTW 80/2	80,00	65,00	9,50	75,00
TTW 90	90,00	70,00	12,50	84,00
TTW 90/1	90,00	70,00	13,00	84,00
TTW 100	100,00	80,00	12,50	94,00
TTW 100/1	100,00	80,00	13,00	94,00
TTW 100/2	100,00	85,00	9,50	95,00
TTW 110	110,00	90,00	12,50	104,00
TTW 115	115,00	95,00	13,00	109,00
TTW 120	120,00	105,00	9,50	115,00
TTW 125	125,00	100,00	15,50	117,00
TTW 125/1	125,00	105,00	12,50	119,00
TTW 140	140,00	120,00	12,50	134,00
TTW 150	150,00	130,00	12,50	144,00
TTW 160	160,00	130,00	19,00	150,00
TTW 160/1	160,00	140,00	12,50	154,00
TTW 170	170,00	150,00	12,50	164,00
TTW 180	180,00	160,00	12,50	174,00
TTW 200	200,00	170,00	20,00	190,00
TTW 200/1	200,00	175,00	16,00	193,00

